

Prep Instructions

The following items will be required for the prep of this activity:

- 2 heavy weight aluminum window screens
- sheet of paper
- wooden frame

Step 1

Take the sheet of paper and fold it in half from top to bottom to create a $8\frac{1}{2}$ in x $5\frac{1}{2}$ in. folded sheet (**Figure 1**).

Step 2

Place the folded piece of paper on top of one of the heavy weight aluminum window screens. Leaving a 1 in. border around the paper, cut the screen into a $7\frac{1}{2}$ in. x $10\frac{1}{2}$ in. rectangle. The folded paper is intended as a sizing guide.

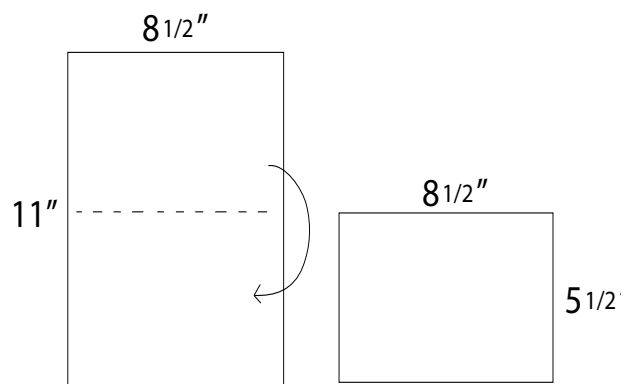

Figure 1

Step 3

A wooden frame can be built from $\frac{3}{4}$ in. wood or a pre-made frame can be used. The inner dimensions of the frame should be $8\frac{1}{2}$ in. by $5\frac{1}{2}$ in. (**Figure 2**). Stretch and staple the window screen material over the wooden frame.

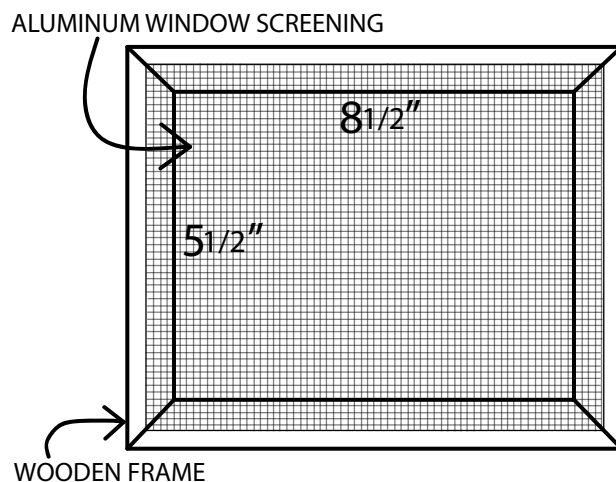

Figure 2